

# CUT'N

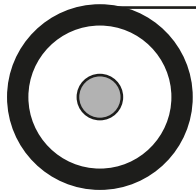

# GRIP

**Fully automatic sheet dispenser**



# CUT 'N GRIP

Cut'n Grip offers a fully automated packaging process and offers a more fluent production process. Extremely easy to use and to manipulate integrating into the control of new or existing palletising lines.



## Fully automatic sheet dispenser

### Manual or completely automatic

The sheets are cut directly from the roll and can be placed automatically or manually in between different products on the pallet. The cutting can be set on the wanted dimensions using the control panel. The Cut'n Grip repeats the procedure sheet per sheet.

### Benefits

- The sheet can be cut in different formats coming from the same roll (The length of the sheet can be set up)
- Optimizes the working time of the robot or the pallet stapler
- No more falling or sticking of sheets like it was before
- Integration of one robot for fully automatic palletisation
- Time optimization 'of stop times using extra wagon
- Easy assembly
- Convenient

### Machine features\*

Machine length	2,800 mm
Machine width	1777 mm
Machine colour	RAL 7035
Machine weight	300 kg
Wagon weight	45 kg
Table length**	1500 mm
Table width	1362 mm
Table height**	1400 mm
Max roll width	1200 mm
Max roll diameter	1000 mm
Max roll weight	600 kg
Cycle time per sheet @ 800 mm	9 sec
Power source	230 V+PE 50 Hz
Power	1 kW
Compressed air connection	10 mm / 6 bar
Consumption compressed air	50 nl/min

\* The given dimensions go for standard systems  
Each project is adapted to the needs of the client.

\*\* Adjustable (option)

The Cut'n Grip is an all-in-one sheet dispenser with automatic cutter. Ideal for cutting big volumes. Grip sheets/paper/cardboards/cutting cardboards in high volumes on roll used in palletising lines.



The roll is placed on a wagon. This wagon can easily be moved and mounted with a new roll. Eventually you can choose for an extra wagon for more tempo (option).



## Automatic treatment with a palletising machine or robot

For big consumers we have Grip Sheet/paper/cardboard in rolls used in palletising lines in combination with a palletising machine or robot. As a specialist in securing loads we can advise you in this matter and can assist you in choosing the packaging machines suitable for your needs. We translate the possibilities of the palletising machine or robot with the suitable packaging machine combined to your product to transport.



## Installation

Cut'n Grip is delivered in a assembly package. Easy to install and little maintenance needed.

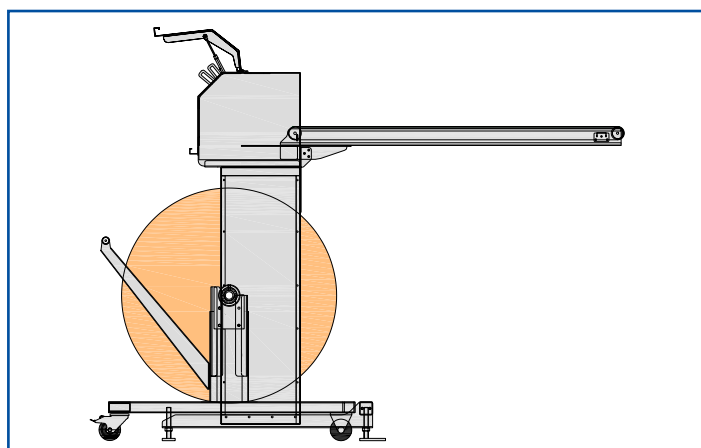

# Machines adapted to the needs of the client

(with supplement / order based)

The standard version of Cut'n Grip is optional and can be adapted to the workspace or your requirements. Length and height of the table can also be adapted to the needs of the client. Machine can be in stainless steel or galvanised and the RAL colour can also be chosen freely.

## Options

Second wagon
Extra strips
"Almost empty" detection photocell
Fault detection indicator on the machine
Cord switch
Emergency stop (potential free) - Option
Sheet length using Profinet
Sheet length using Profibus
20 Watts heating with thermostat in the controls
Frequency regulator for capacity improvement
Sheet transport photocells to the end
Compressor with controls (ready to connect)
Compressor without controls (EOM)
Stainless steel or galvanised
Customer-specific colours



Distributor:



De Aaldor 24  
4191 PC Geldermalsen

T: +31 (0)345 800 800  
F: +31 (0)345 800 850  
E: info@tallpack.nl  
www.tallpack.nl



3 Impasse des Filatures  
27290 Pont-Authou,  
France

T: + 33 (0) 2 32 42 70 06  
F: + 33 (0) 2 32 57 69 12  
E: info@endupack.com  
www.endupack.com